

12. Lower the vehicle until the weight of the vehicle is resting on the wheels and tires (curb height).
13. Tighten the new spring shackle-to-frame nut and bolt.
Torque : 173 lb.ft (235 Nm)

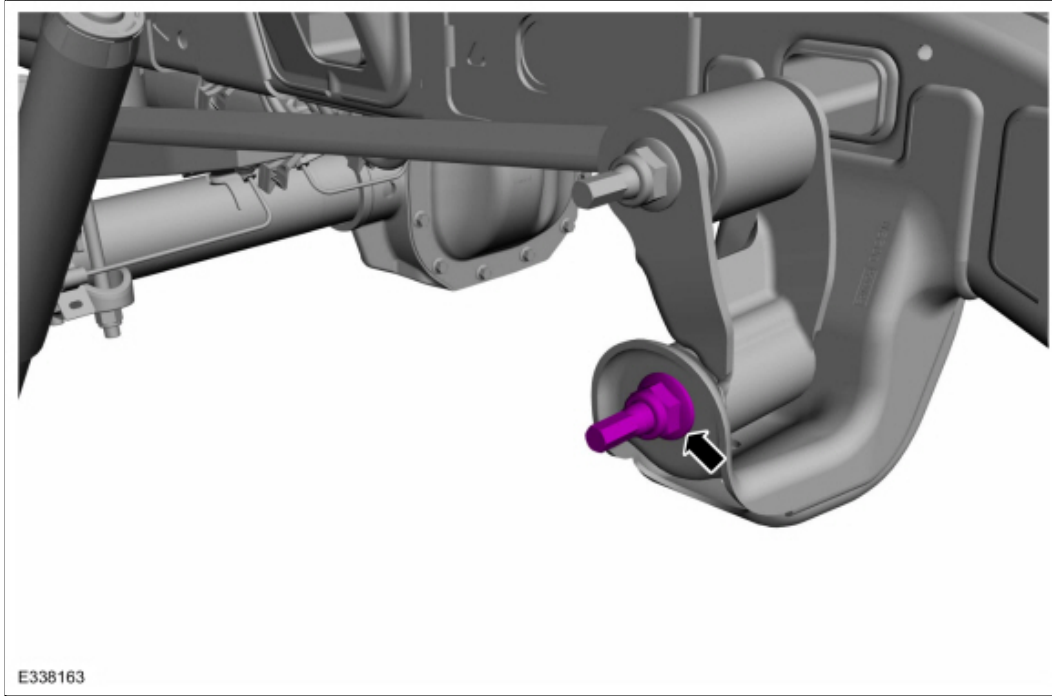

14. Tighten the new spring-to-frame nut and bolt.
Torque : 258 lb.ft (350 Nm)

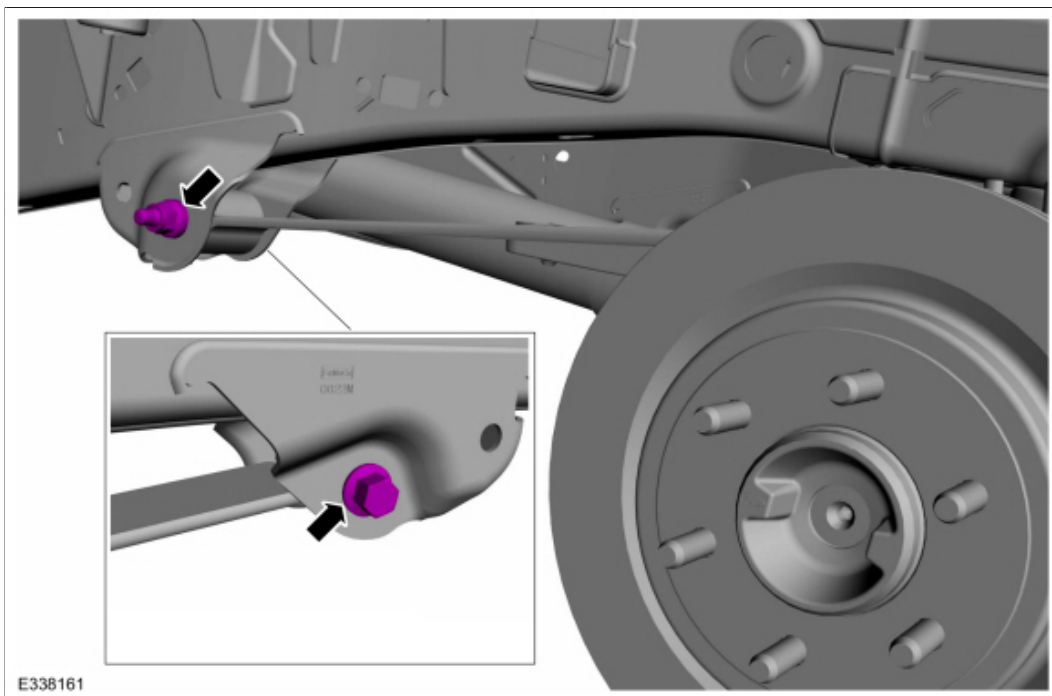

15. Tighten the new shackle-to-spring bolt and nut.
Torque : 173 lb.ft (235 Nm)

